



Main Features:

- Frequency Range: 1.0 to 2.0 GHz.
- Typical values: Pout 50 dBm, Gain 42 dB
- Power Added Efficiency: 30%
- Gain Flatness ± 2 dB typ
- RF connectors (I/O): SMA Female
- Several mounting options

PPA-0100-0200-50

The PPA-0100-0200-50 is a High Power Amplifier providing an output power of 50 dBm and a gain of 42 dB. The compact size and modularity makes it ideal for a wide range of applications.

Typical applications:

- Wireless communication equipment
- Test and measurement equipment
- Navigation and aerospace
- Commercial radars
- General-purpose transmitter amplification

Performance

Parameter	Value			Units
	Min	Typ	Max	
Frequency	1.0	-	2.0	GHz
Output Power		50		dBm
Small Signal Gain	40	42	44	dB
Gain Flatness	-	± 2	-	dB
VSWR input	1.4	-	1.9	-
DC Voltage		28		V
RF Connectors	SMA Female IN/OUT			
Operating Temperature	-45 to +85 °C			
Storage Temperature	-55 to 125 °C			

Specifications at a case temperature of 25°C at 32 V

Saturated Output Power

Figure 1 shows saturated output power measurement as a function of frequency at low (-45°C), normal (25°C) and high (70°C) temperatures.

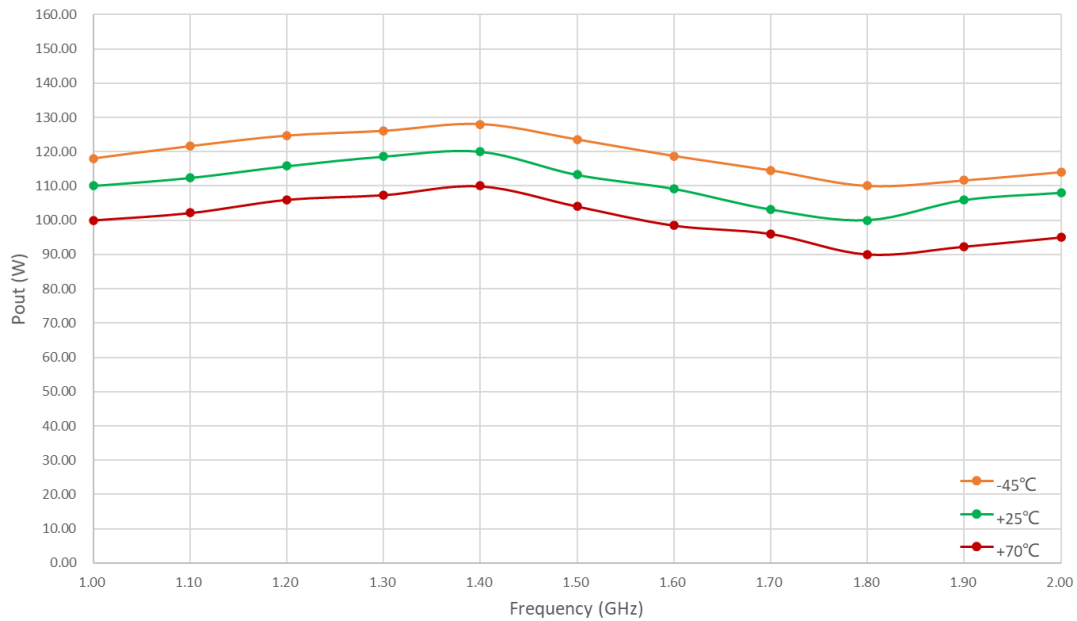

Figure 1: PPA-0100-0200-50 Psat

Small Signal Gain Vs Temperature

Figure 2 shows small signal gain measurement as a function of frequency at low (-45°C), normal (25°C) and high (70°C) temperatures.

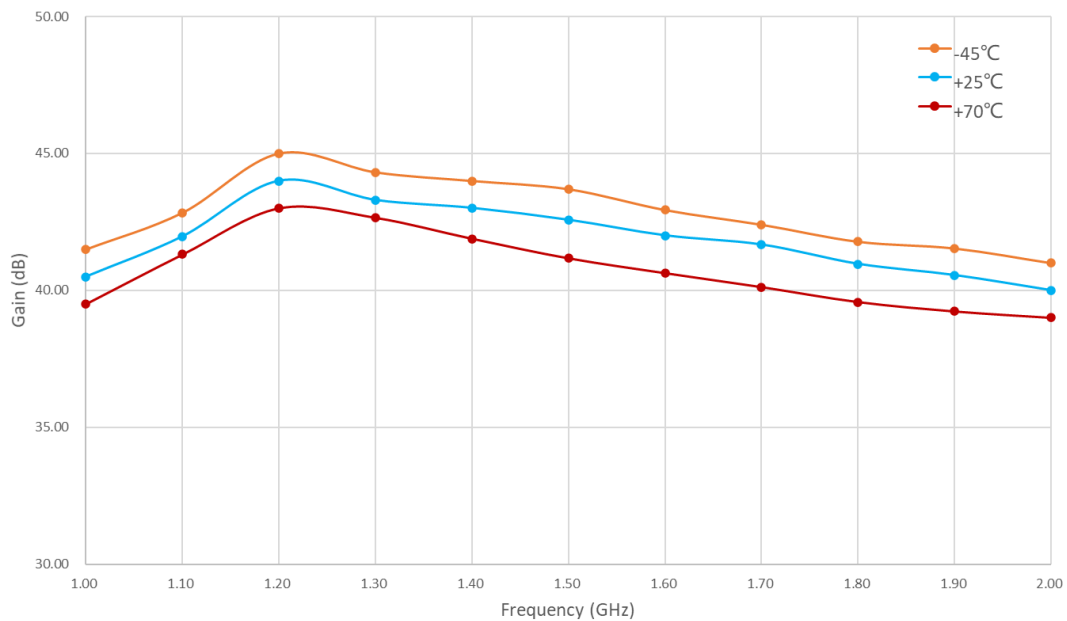

Figure 2: PPA-0100-0200-50 Small Signal Gain Vs Temperature

Input VSWR

Figure 3 shows input (S11) VSWR as a function of frequency at environment temperature (25°C).

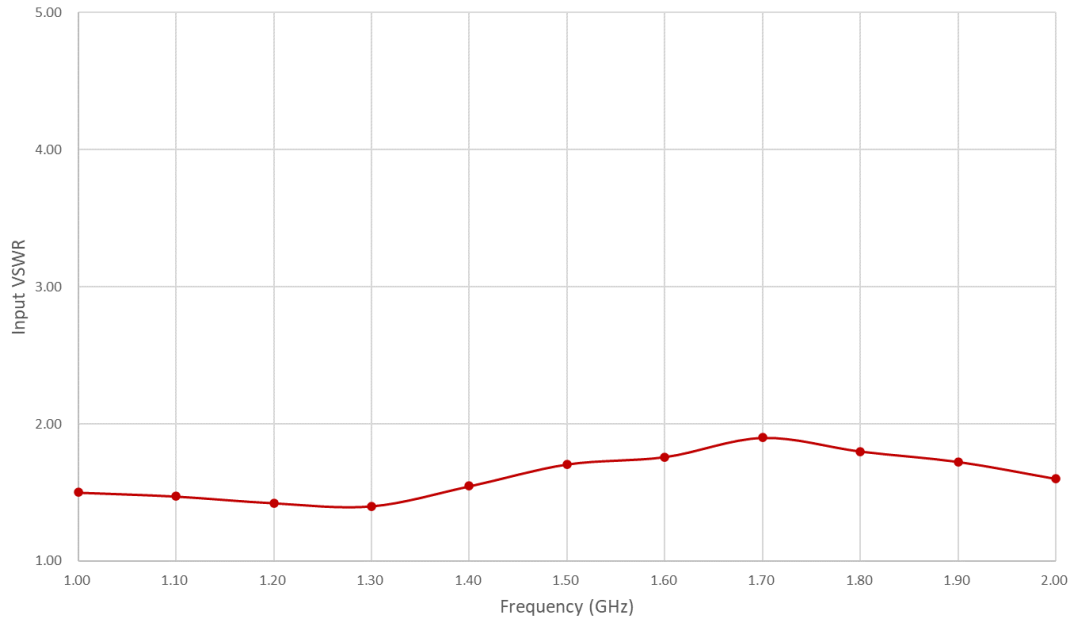

Figure 3: PPA-0100-0200-50 Input VSWR

P.A.E

Figure 4 shows P.A.E as a function of frequency at environment temperature (25°C)

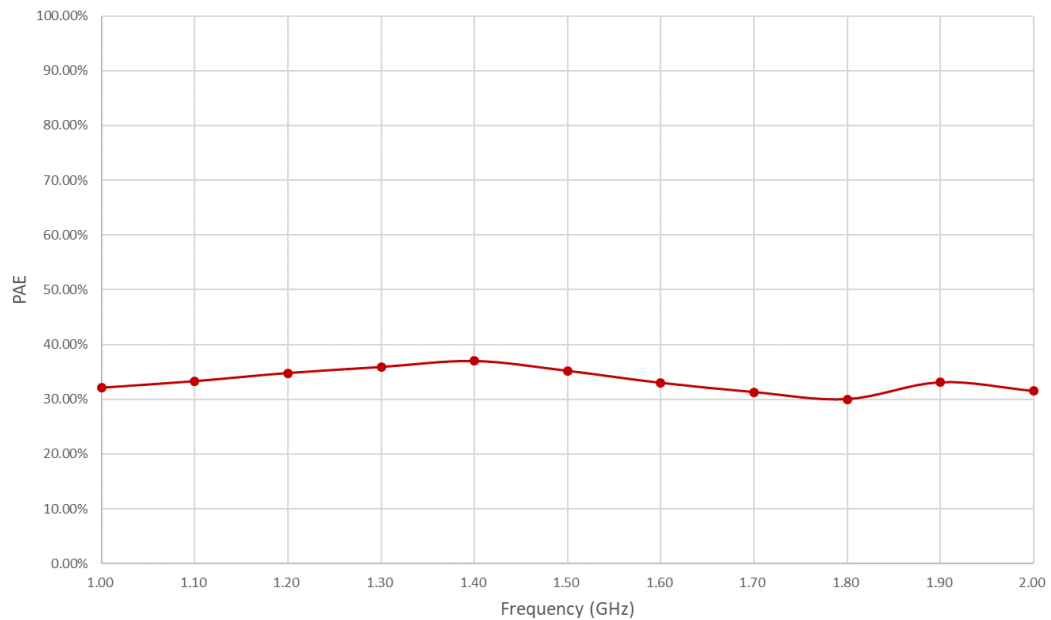

Figure 4: PPA-0100-0200-50 P.A.E

Absolute Maximum Ratings

Condition	Value
DC Voltage	+35 VDC
Maximum Input Power (CW)	+20 dBm
Operation temperature (at case)	-40 to 70 °C
Storage temperature	-55 to 125 °C

- Stress above these ratings may cause permanent damage to the device.
- It is final user responsibility to maintain the amplifier within the specified ranges.

Measurements Conditions

All measurements provided in this report were performed at the following conditions:

Condition	Value
Temperature (DUT ON)	25 °C ± 1°C
Humidity	44% ± 10%
DUT Warm up time	30 min
DUT minimum operation time	24 hours
Test equipment warm up time	2 hours
Additional temperature cycles in climatic chamber (DUT OFF)	-40°C to 85°C

Mechanics and Housing

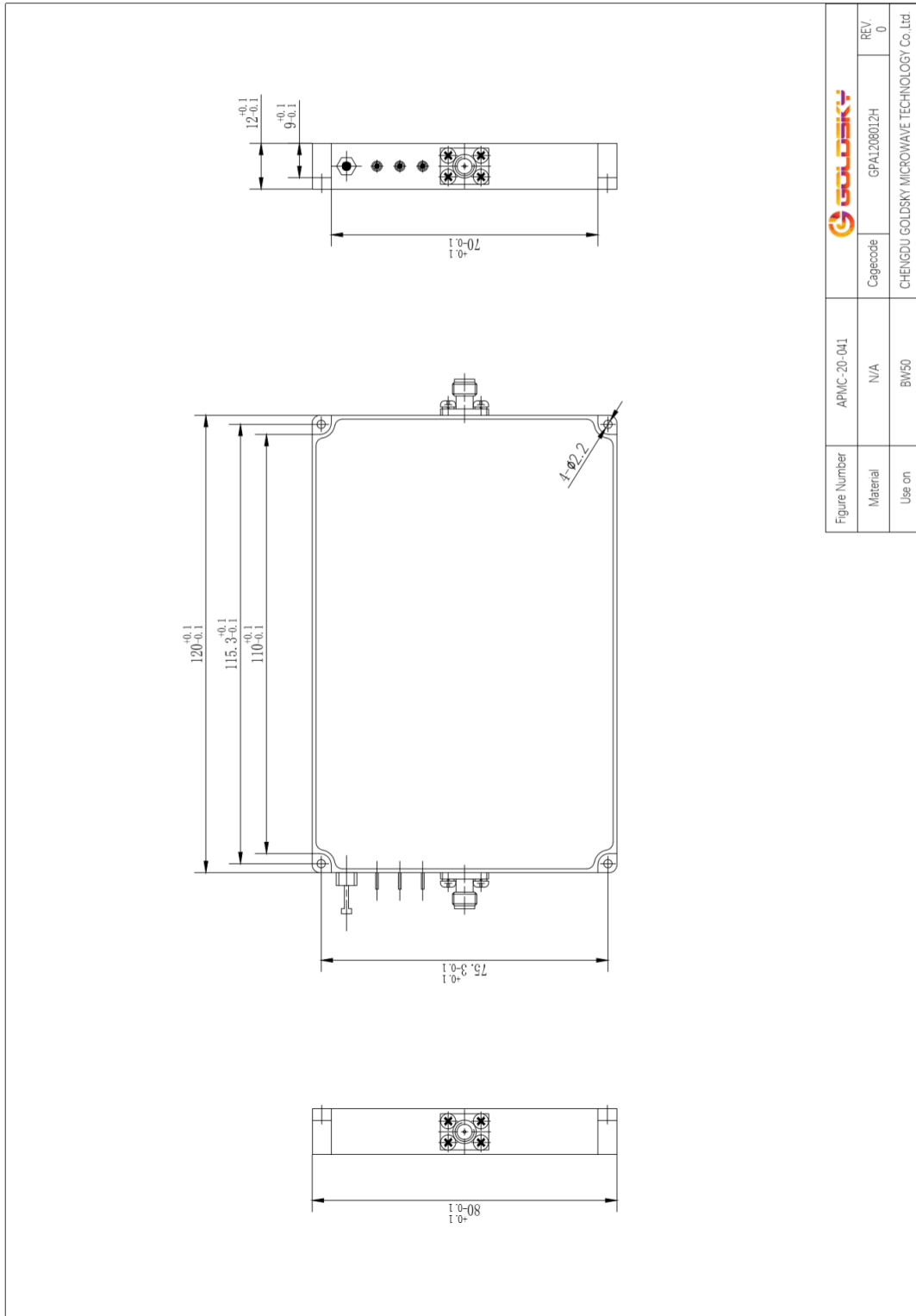

Figure Number	APMC-20-041	GOLDSKY	REV	0
Material	N/A	Cagecode	GPA1208012H	
Use on	BW50	CHENGDU GOLDSKY MICROWAVE TECHNOLOGY Co.,Ltd		



Identifier	Specification
IN	Signal Input
OUT	Power Output
GND	Ground
Vcc1	DC Supply +32V
Vcc2	DC Supply +32V
EN	ENABLE (can be used for pulse modulation)

Model Number Codification

Model Number

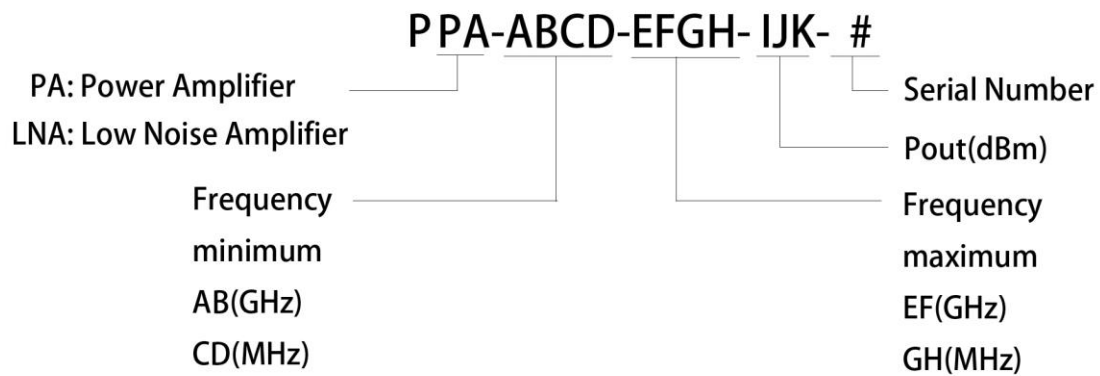



20200429_rev1.0

Copyright © 2020 GoldSky MW Technologies. All rights reserved. This information is commercial and indicative, subject to change without notice